Appendix A – WDT1789

[REDACTED]

[REDACTED]

Queue Cluster 14 Phase I Report

September 15, 2022

This study has been completed in coordination with the California Independent System Operator Corporation (ISO) per Southern California Edison Company's Wholesale Distribution Access Tariff (WDAT), Attachment I Generator Interconnection Procedures (GIP)

Interconnection Study Document History

No.	Date	Document Title	Description of Document
1	09/15/2022	Queue Cluster 14 Phase I Appendix A Report	Final Phase I interconnection study report

CONTENTS

A. Introduction	1
B. Report Objective	1
C. Description of Generating Facility	2
D. Study Assumptions	5
E. Study Results	8
F. Affected Systems	10
G. Deliverability Assessment Results	11
H. Metering	11
I. Interconnection Facilities, Network Upgrades, and Distribution Upgrades	11
J. Cost and Construction Duration Estimate	12
K. In-Service Date and Commercial Operation Date Assessment	14

ATTACHMENTS

Attachment 1: Interconnection Facilities, Network Upgrades and Distribution Upgrades	17
Attachment 2: Escalated Cost and Time to Construct for Interconnection Facilities, Reliability Network Upgrades, Delivery Network Upgrades, and Distribution Upgrades	18
Attachment 3: Allocation of Network Upgrades for Cost Estimates and Maximum Network Upgrade Cost Responsibility	19
Attachment 4: SCE's Interconnection Handbook	20
Attachment 5: Short-Circuit Duty Calculation Study Results	21
Attachment 6: Not Used	22
Attachment 7: Subtransmission Assessment Report	23
Attachment 8: Distribution Assessment Report	24

A. INTRODUCTION

██████████, the Interconnection Customer (“IC”), submitted a completed Interconnection Request (“IR”) to Southern California Edison (“SCE”), the Distribution Provider, for their proposed ██████████. The IC’s IR stipulated Energy Only Deliverability Status (“EODS”) for the Generating Facility. In addition, the IC requested an In-Service Date (“ISD”) and Commercial Operating Date (“COD”) ██████████, respectively. However, the actual in-service dates for the Generating Facility will depend on the duration required for: licensing, engineering, detailed design, and construction associated with the facilities required to interconnect the Generating Facility. The duration for these activities would commence after the Generation Interconnection Agreement (“GIA”) for the Generating Facility has been executed or filed at the Federal Energy Regulatory Commission (“FERC”) for acceptance and funded.

In accordance with FERC approved SCE’s Wholesale Distribution Access Tariff (“WDAT”) Attachment I Generator Interconnection Procedures (“GIP”), the Generating Facility was grouped with Queue Cluster 14 (QC14) Phase I projects to determine the impacts of the group as well as impacts of the Generating Facility on SCE’s Distribution System and the ISO Grid. An Area Report, Subtransmission Assessment Report, and Distribution Assessment Report have been prepared separately to discuss the combined impacts of all projects on the ISO Grid and impacts to non-ISO controlled distribution facilities served out of the Antelope 66 kV System¹, respectively. This Appendix A report focuses only on the impacts or impact contributions of the Generating Facility to SCE’s Electric System and is not intended to supersede any contractual terms or conditions specified in the forthcoming GIA.

B. REPORT OBJECTIVE

SCE performed a QC14 Phase I Study that included the Generating Facility, and this report addresses the results of the analysis.

The report provides the following:

1. Transmission and Distribution system impacts attributed to the Generating Facility.
2. System reinforcements or mitigation necessary to address the adverse impacts attributed to the Generating Facility under various system conditions.
3. A list of required facilities and a good faith estimate of the Generating Facility’s cost responsibility and SCE’s construction schedule², assuming SCE is constructing the required facilities. Such information is provided in Attachment 1 and Attachment 2 as separate documents in the Appendix A report package for the Generating Facility. Specifically, the facilities that will be installed by SCE and the IC are detailed in Attachment 1.
4. Identification of potential short circuit duty impacts to Affected Systems served from the Transmission, Subtransmission or Distribution System.

¹ This includes non-ISO controlled Distribution System facilities at the subtransmission level (66 kV or 115 kV) and low voltage facilities that are 50 kV and below.

² It should be noted that construction is only part of the duration of months specified in the study, which includes final engineering, licensing, and other activities required to bring such facilities into service. These durations are from the execution of the GIA, receipt of: all required information, funding, and written authorization to proceed with design and engineering, procurement, and construction from the IC as will be specified in the GIA to commence the work.

C. DESCRIPTION OF GENERATING FACILITY

Generating Facility: all equipment and facilities comprising the IC's [REDACTED] located in the City of [REDACTED], California, as disclosed by the IC in its IR, as may have been amended during the Interconnection Study process, as summarized below:

Table C.1: [REDACTED]

[REDACTED]	
[REDACTED]	
[REDACTED]	
[REDACTED]	
[REDACTED]	
Generating Facility Output:	Solar PV
Total rated (gross) capacity at generator/inverter/converter terminals:	[REDACTED] [REDACTED]
Total net capacity requested at Interconnection Customer's switchboard:	[REDACTED]
Total net capacity requested at Point of Interconnection:	[REDACTED]

Generation Export Limit for the Generating Facility

The IC requested a total net output capacity of [REDACTED] MW as measured at the POI. The IC and SCE acknowledge that should the Generating Facility exceed this value or if the Generating Facility is capable of exceeding this value, the IC shall be required to install, own and maintain a control limiting device or, alternatively, by means of configuring the Generating Facility's control system, as approved by SCE, that will ensure the Generating Facility complies with these restrictions.

The scope of facilities that will be installed by SCE and the IC for physical interconnection of the Generating Facility, to provide for the requested net MW output at the POI are detailed in Attachment 1 to this Appendix A report. Figure C.1 illustrates the Generating Facility and Figure C.2 illustrates the location of the Generating Facility. Additional Generating Facility information is provided in Table C.2.

Figure C.1: [REDACTED]

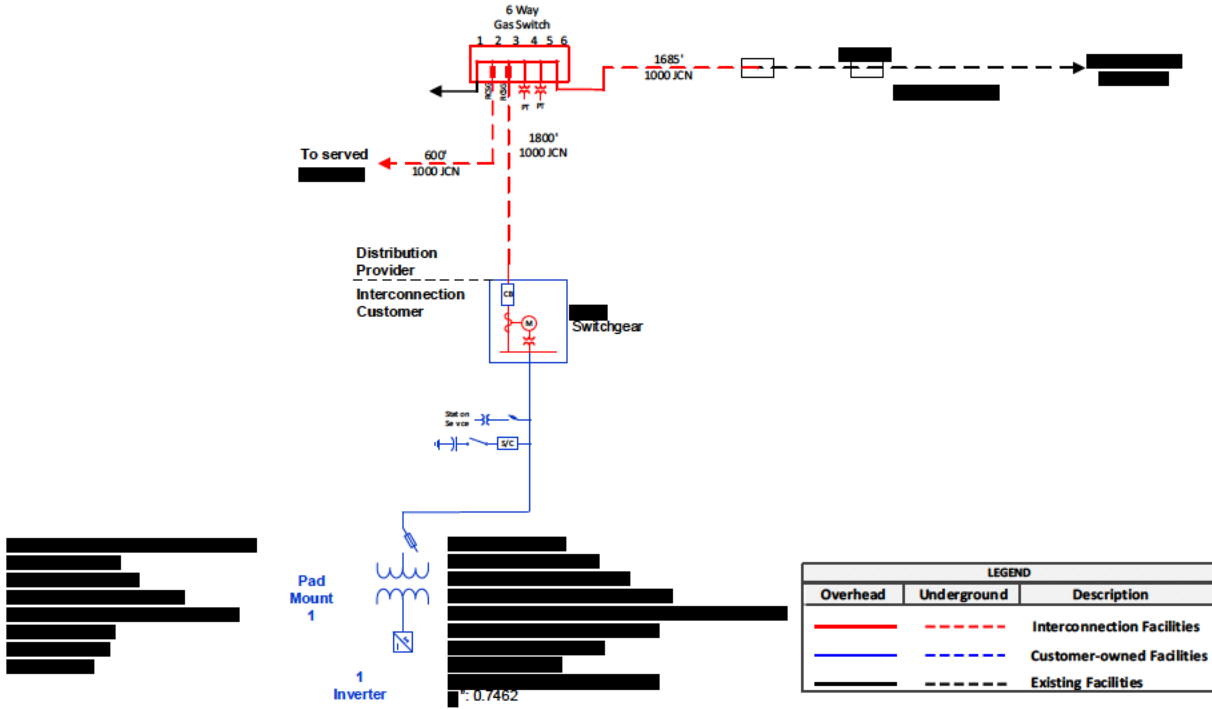

Figure C.2: [REDACTED]

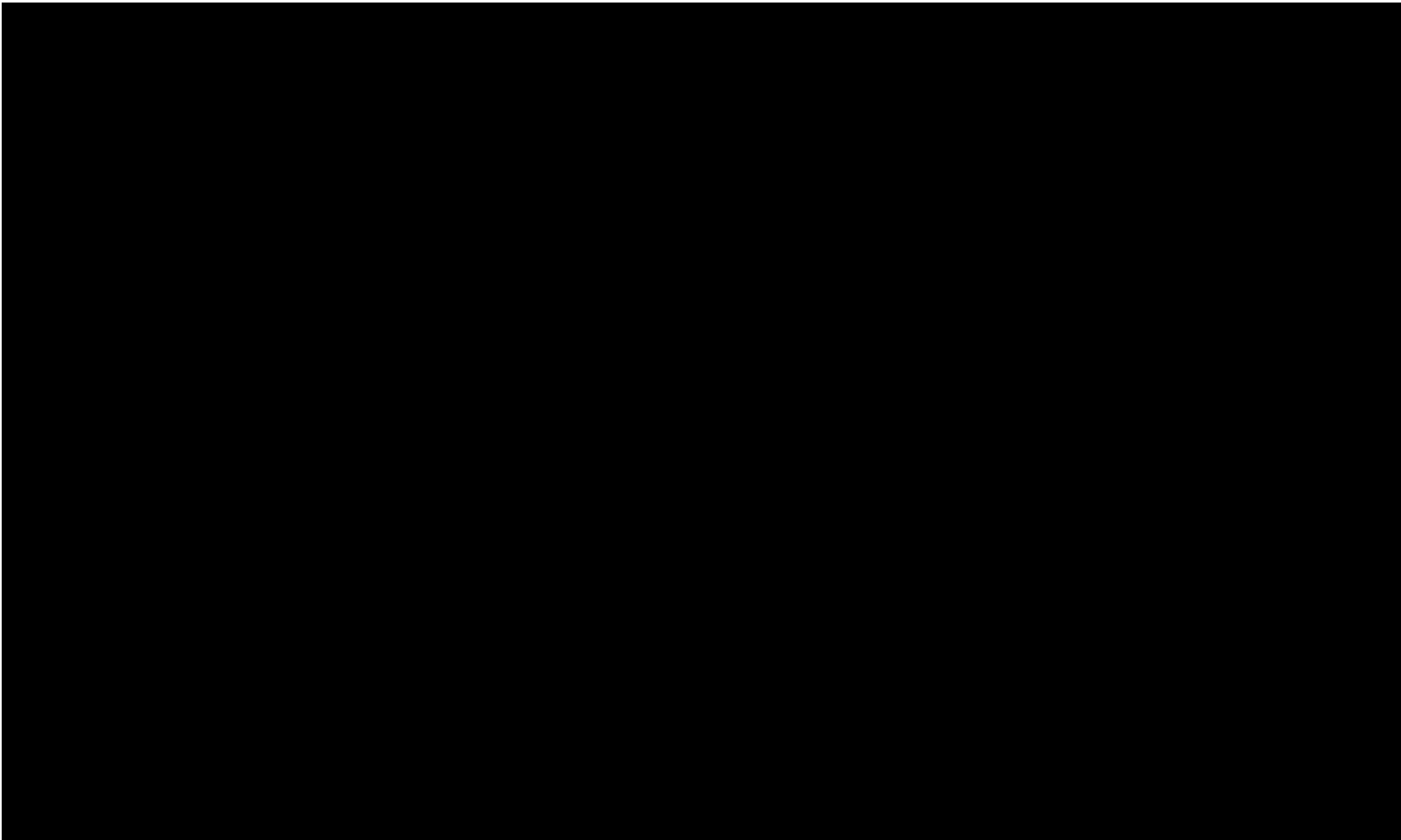

Table C.2: [REDACTED]

Generating Facility Location	[REDACTED]
SCE's Planning Area	[REDACTED]
SCE's Subtransmission System	[REDACTED]
Interconnection Voltage	[REDACTED]
POI	[REDACTED]
High Fire Risk Area	[REDACTED]
Maximum requested export capacity at POI	[REDACTED]
Pad-Mount Transformer(s)	[REDACTED]
Generator/Inverter/Converter Data	[REDACTED]
Auxiliary Load and/or Station Light and Power	[REDACTED]

The Generating Facility was modeled as described in Table C.1 and Table C.2 above.

D. STUDY ASSUMPTIONS

For detailed assumptions regarding the transmission, subtransmission and distribution system, please refer to the QC14 Phase I Area Report, Subtransmission Assessment Report, and Distribution Assessment Report, respectively. Below are the assumptions specific to the Generating Facility:

I. Environmental Activities, Permits, and Licensing.

Table D.3 Environmental Activities & Licensing evaluation per SCE Facilities or Upgrades

SCE Facility or Upgrade Classification	Assumed Licensing (y/n)	Environmental Activities Assumed Roles and Responsibilities		Declaration Required (y/n)
		IC/SCE-Shared	SCE Only	
IF	N	X		Y
DU				
Other				
RNU	[REDACTED]			[REDACTED]
LDNU				
ADNU ³				
Shared DU			X	[REDACTED]

³ For the Phase I Study, it was assumed that SCE would be constructing the ADNUs. For a detailed explanation on who can construct the ADNUs please refer to GIDAP Section 14.3.

For further details on the environmental evaluation and permitting/licensing requirements for generator interconnection projects, refer to Appendix K of the Area report.

If no “X”, “Y”, or “N” is entered in a specific row of Table D.3, then assume no environmental scope of work or costs would apply to such SCE facilities disclosed in Attachment 1.

Assumed Licensing:

- a. If yes is indicated in Table D.3, SCE assumes construction of SCE’s Interconnection Facilities (“IF”) and/or Distribution Upgrades (“DU”) needed to interconnect the Generating Facility will require a California Public Utilities Commission (“CPUC”) license.
- b. If no is indicated in Table D.3, SCE assumes construction of SCE’s IF and/or DU needed to interconnect the Generating Facility will not require a CPUC license.
- c. Such assumptions will be reviewed and verified after execution of a Generator Interconnection Agreement (“GIA”) when detailed engineering and environmental review occur.

Environmental Activities Assumed Roles and Responsibilities:

- i. If “IC/SCE-Shared” is marked in Table D.3:

SCE Scope of Work

1. SCE will act as the lead for regulatory agency communication for permits issued to SCE covering such SCE facilities.
2. If licensing is assumed, SCE will file for an “expedited” Certificate of Public Convenience and Necessity or “expedited” Permit to Construct by attaching the IC’s certified final California Environmental Quality Act (“CEQA”) document with SCE’s scope of work sufficiently incorporated in lieu of a Proponent’s Environmental Assessment (“PEA”). If a CEQA document is not required for the Generating Facility or if the Generating Facility’s CEQA document does not sufficiently incorporate SCE’s scope of work, SCE may be required to prepare a PEA for SCE’s scope of work. In such cases, SCE’s assumed environmental work and licensing level of effort will increase, resulting in the need to update cost and duration estimates, and potentially amend the GIA.
3. SCE environmental activities may include, but are not limited to, the following:
 - a) Perform all environmental studies and construction monitoring of SCE internal substation construction activities and provide study results to the IC for inclusion in its environmental documents, if applicable.
 - b) Collaborate with the IC during the environmental study phase on the IC’s proposed study methodologies and findings, as studies are being planned and performed for SCE’s scope of work.
 - c) Review IC’s CEQA and/or National Environmental Policy Act (“NEPA”) documents, technical studies, surveys, and other environmental documentation to ensure SCE’s scope of work is adequately described in such documents (IC will include SCE’s scope of work in its environmental documents. If the Generating Facility’s CEQA and/or NEPA documents do not sufficiently incorporate SCE’s scope of work, SCE’s assumed environmental work and permitting level of effort may increase, resulting in the need to update cost and duration estimates, and potentially amend the GIA).
 - d) Review SCE’s internal existing technical reports/documents when available.
 - e) Prepare SCE’s project description, including scope changes during permitting/pre-construction or construction.

- f) Communicate scope changes to the IC’s environmental team and discuss/approve subsequent actions including new surveys as necessary.
- g) Complete General Order 131-D Consistency Determination and Environmental Evaluation.
- h) Regulatory agency communication, consultation, reporting, and acquisition of SCE permits addressing SCE's facilities and scope of work.
- i) Prepare environmental requirements for construction clearance.
- j) Develop communication plan.
- k) Perform pre-construction coordination field visit.
- l) Provide Environmental Awareness/Worker Environmental Awareness Program (“WEAP”) training.
- m) Perform construction monitoring oversight.
- n) Complete construction and post-construction site assessments.

IC Scope of Work

1. IC will perform all environmental studies and prepare draft environmental permit applications related to the installation of such SCE facilities, except for the SCE internal substation activities as described above. The IC’s responsibilities include as applicable, but are not limited to: notifications to the Native American Heritage Commission (“NAHC”) and follow-up notifications to the tribes and individuals in the NAHC contact list; performing cultural and paleontological resources records searches, cultural resources inventories (survey and recording), testing and evaluation and/or data recovery of archaeological sites, and appropriate documents in the form of inventory reports, research design, and/or data recovery reports; cultural and paleontological monitoring when/if required, and arranging curation agreements for artifacts and fossil specimens collected; performing a California Natural Diversity Database search, habitat assessment, and protocol or focused surveys for species with the potential of occurring in identified suitable habitat; conducting jurisdictional delineations for wetlands and other regulated waters; preparing draft environmental permit applications, pre-construction biological resource surveys for such SCE facilities, biological resource monitoring during construction of such SCE facilities; mitigation costs including, but not limited to, offsite/compensatory mitigation and onsite restoration, and developing mitigation plans or other environmental reports or submittals to support installation of such SCE facilities.
 2. Prior to commencing work and during execution of work, the IC should collaborate and obtain SCE concurrence on all work outlined above. Should the IC-performed environmental studies, surveys, or construction monitoring not meet the Federal or State industry standards in accordance with Applicable Laws and Regulations, and as determined by SCE, the IC shall be obligated to remedy deficiencies under SCE’s direction.
- ii. If “SCE Only” is marked in Table D.3:
1. SCE will perform all required environmental studies, prepare environmental permit applications, obtain required environmental permits, and perform required monitoring of all SCE construction activities, and undertake habitat mitigation as required, including, but not limited to, offsite/compensatory mitigation and onsite restoration, related to the installation of such SCE facilities.

2. Under certain circumstances, such SCE facilities may need to be described and analyzed as part of the IC's CEQA and/or NEPA documents for the Generating Facility. Further coordination to discuss these circumstances may occur during GIA negotiations and/or after GIA execution. Any changes to the environmental and licensing assumptions may result in the need to update cost and duration estimates, and potentially amend the GIA.

Declaration Required:

As a requirement for Interconnection Customers' shared responsibility to perform the Environmental Activities for SCE-owned IF and DU as disclosed above, and to ensure proper accounting of costs used in the calculation of the ITCC and Operations & Maintenance ("O&M") charges, referred to as an Interconnection Facilities Charge and/or a Distribution Upgrades Charge, if applicable, in the forthcoming GIA for the Generating Facility, the IC is required to complete and submit an Environmental Services Costs Declaration for SCE-owned IF and/or DU required to interconnect the Generating Facility. An authorized representative of the IC will sign the declaration attesting to the actual costs spent on environmental services work that would otherwise have been performed by SCE for SCE-owned IF and DU (if applicable) required to interconnect the Generating Facility.

The declaration shall be provided to SCE by a specified date in the Generating Facility's forthcoming GIA Appendix B - Milestone table. Should the IC fail to provide the declaration by the specified deadline, SCE will hold the IC in default of the GIA pursuant to the terms therein. The costs stated by the IC in the declaration, once approved, will be used by SCE to adjust the ITCC and the applicable monthly O&M charges for the Generation Facility and will be reflected via an amendment to the GIA upon true-up.

The information stated in the declaration is subject to review and/or audit by SCE pursuant to the terms and conditions in the forthcoming GIA. Should an audit be deemed necessary by SCE, the IC will need to provide supporting documentation (copies of invoices/receipts) to substantiate the costs stated in the declaration within ten (10) business days from receipt of.

II. Other Items to Consider:

- NA.

E. STUDY RESULTS

1. ISO Grid

a. Generation Export Analysis

i. Steady State Power Flow Reliability Assessment

The results of the ISO Grid reliability analysis indicate that the Generating Facility contributes to overloads under normal, and/or single contingency, and/or multiple contingency conditions. A combination of congestion management, Area Deliverability Network Upgrade ("ADNU"), Local Delivery Network Upgrades ("LDNU"), and CRAS/RAS are required to mitigate the power flow impacts of the Generating.

Although the generating facility did contribute to various overloads, the approved upgrades mainly focus on ADNUs and RNU that only require generating tripping infrastructure for TOT projects. Thus for RNU no upgrades to the ISO Grid were assigned to the Generating Facility, as a WDAT project.

For information on any LDNU/ADNU assigned to the Generation Facility, if applicable, please refer to section G in this report.

ii. Deliverability Assessment

Section G – Deliverability Assessment Results of this report provides information on any Delivery Network Upgrades (Local or Area) assigned to the Generating Facility, if any.

iii. Transient Analysis

In the “Supercluster Interconnection Procedures” paper⁴, the ISO, in coordination with the PTOs, established reasonable study scenarios and dispatch assumptions for the steady state (thermal and voltage) analysis. Total generation inside the study area will be limited to produce meaningful study results. No system stability analysis was performed in Phase I, however a system stability analysis will be conducted as part of the Phase II Study.

iv. Short Circuit Duty Analysis

The SCD evaluation at the Bulk Level did not identify any overstressed circuit breakers requiring mitigation.

2. Non-ISO controlled Subtransmission System [REDACTED]

a. Generation Export Analysis

i. Steady State Power Flow Analysis

The results of the Subtransmission Assessment indicated that the Generating Facility does not contribute to any overloads under normal, single contingency, and multiple contingency conditions. The details of the analysis is provided in the corresponding Subtransmission Assessment Report.

ii. Post Transient Voltage Stability Analysis

As noted previously in Section E.1.a.ii, no system stability analysis was performed in the Phase I study, however a system stability analysis will be conducted as part of the Phase II Study.

iii. Short Circuit Duty (SCD) Analysis

The SCD evaluation at the Subtransmission System level did not identify any overstressed circuit breakers requiring mitigation.

a. SCD Considerations

The Generating Facility was found to be dependent upon the installation of additional SCD upgrade(s) listed below. Although the IC is not financially responsible for the SCD

⁴ <http://www.caiso.com/Documents/IssuePaper-DraftFinalProposal-SuperclusterInterconnectionProcedures.pdf>

upgrade(s) listed below, the Generating Facility will need to wait until the project is complete to be placed in-service.

Current SCE Sponsored SCD Upgrades

SCD Upgrade	Estimated COD
[REDACTED]	[REDACTED]

3. Non-ISO controlled Distribution System [REDACTED]

a. Generation Export Analysis

i. Steady State Power Flow Analysis

The study specific to this Generating Facility evaluated the impacts on the circuit, including the distribution system configuration modifications, and substation which provide and/or support the POI of the Generating Facility. Detailed study results, provided in the Distribution Assessment Report, indicate that the Generating Facility triggers a thermal overload on the [REDACTED] circuit along an underground segment of #2 Cross-Linked Polyethenel cable due to the reverse power flow by the inclusion of the. To mitigate these identified issues, the following upgrades discussed in the Distribution Assessment Report and assigned to the Generating Facility involve:

- Reconductor approximately 1,345 feet of 2 CLP underground cable with 1000 Jacketed Concentric Neutral (JCN) cable
- Reprogramming of existing SEL-351 relay and Substation Automation System (SAS) point addition

Please refer to Attachment 1 and Attachment 2 for additional scope and costs information.

ii. Voltage Analysis

The study determined that the addition of the Generating Facility does not result in any CPUC Rule 2 Voltage requirements under maximum generating operating conditions at unity power factor during minimum and peak loading conditions.

iii. Protection

The study determined that no additional protection related upgrades or modifications are required in support of the Generating Facility beyond the standard protection.

iv. Short Circuit Duty Analysis

The SCD evaluation at the Distribution level did not identify any overstressed circuit breakers requiring mitigation that is allocated to the Generation Facility.

F. AFFECTED SYSTEMS

The Short Circuit Duty studies performed for the ISO Grid, Subtransmission System, and Distribution System have identified SCD impacts on Affected Systems. Specific to this Generating Facility, the corresponding SCD contribution to the Affected Systems is provided in Table F.1 below.

Table F.1: Short-Circuit Duty Evaluation of Neighboring Utilities Impacted by the Generating Facility

Substation	Voltage (kV)	Entity	Generating Facility Impact	
			3-Phase (kA)	Single Line-to-Ground (kA)

Refer to the Area Report, Subtransmission Assessment Report, and Distribution Assessment Report for additional details.

G. DELIVERABILITY ASSESSMENT RESULTS

Not applicable, due to the IC selecting Energy Only Deliverability Status for the Generating Facility.

H. METERING

The IC did not provide SCE a detailed one-line diagram prior to the Phase I Studies that shows the Generating Facility’s proposed metering configuration (“metering one-line”). As a result, the Phase I Study metering scope and costs was based on preliminary engineering and design and subject to change. Therefore, the IC, per SCE’s Interconnection Handbook Section 6.3 and GIP Section 9.3, shall provide SCE with a detailed metering one-line ten (10) Business Days following the Phase I Results Meeting. The approved metering one-line will enable SCE to determine the number of meter sets required to meter the Generating Facility in compliance with its metering tariff(s) requirements.

If the IC fails to provide an approved metering one-line in accordance with SCE’s Interconnection Handbook Section 6.3 and GIP Section 9.3, the Phase II Study metering scope and cost will be based on a proxy methodology that would presumably enable SCE to comply with its metering tariff(s) requirements. Since the IC is required to comply with SCE’s Interconnection Handbook and GIP, the IC’s Generating Facility’s metering configuration will be evaluated post Phase II or post GIA. If post GIA, finalizing the Generating Facility’s metering one-line and determining the number of meter sets required to comply with metering tariff(s) requirements will be performed in parallel with the engineering and design phase of the Generating Facility. This post GIA analysis may result in additional metering scope and cost and may impact the IC’s requested ISD and COD. Any change to the Generating Facility’s interconnection configuration or technology after the Phase II study, including the metering configuration, will require the IC to submit an MMA request in accordance with the GIP.

I. INTERCONNECTION FACILITIES, NETWORK UPGRADES, AND DISTRIBUTION UPGRADES

Please see Attachment 1 for SCE’s IF’s, RNU’s, Delivery Network Upgrades⁵ (DNUs), and DUs allocated to the Generating Facility for physical interconnection, to provide for the requested net MW output at the POI, the requested Deliverability, and Capacity. Please note that SCE considered current system configuration, approved SCE sponsored projects, and all queued generation in determining scope for IFs and/or plan of service but will not “reserve” the identified scope of upgrades for the proposed POI unless a GIA is executed per the specified timelines shown in Table K.1.

⁵ At the IC’s discretion, the IC or parties other than SCE pursuant to Section 10.2 under GIP may construct an Option (B) Generating Facility Area Delivery Network Upgrades (ADNUs) not allocated TP Deliverability. If SCE does not construct the ADNUs, the IC is not required to make the third Interconnection Financial Security posting to SCE pursuant to Section 4.8.4.2.1 under GIP.

J. COST AND CONSTRUCTION DURATION ESTIMATE

1. Cost Estimate

The Generating Facility’s estimated interconnection costs, adjusted for inflation and provided in 'constant' 2022 dollars escalated to the Generating Facility’s feasible COD (as identified below in Table K.1), are provided in Attachment 2, including the applicable charges for Charging Distribution Service, and the Generating Facility’s allocated cost for shared network upgrades are provided in Attachment 3 to this Appendix A report. The interconnection costs will be in the forthcoming GIA for the Generating Facility. However, should there be a delay in executing the GIA beyond 2021, a new cost estimate adjusted for inflation will be required and reflected into the forthcoming GIA for the Generating Facility.

2. Preliminary Durations for SCE Engineering, Design, and Construction to enable interconnection of the Generating Facility

The duration shown in Table J.1 represents the estimated time needed for SCE to design, procure, and construct the applicable facilities with the start date of the duration based on the effective date of the GIA; and necessarily include timely receipt of all required information and written authorizations to proceed (ATP), and timely receipt of construction payments and financial security postings and other milestones. The durations for the facilities identified for the Generating Facility is as follows:

Table J.1 Estimated Execution Duration for Generating Facility

Facilities	Description	Duration (months) ⁶	Notes
Interconnection Facilities (IF)	Facilities described in Section 1.b of Attachment 1	■	■
Reliability Network Upgrades (RNU)	No required RNU were identified in the Phase I Interconnection Study	■	■
Stand Alone Network Upgrades (SANU)	NA	■	■
Area Delivery Network Upgrades (ADNU)	NA	■	■
Local Delivery Network Upgrades (LDNU)	NA	■	■
Distribution Upgrades (DU)	DUs described in Section 3 of Attachment 1	■	■

⁶ **Short Circuit Duty Mitigation Durations:** It is important to note that short-circuit duty upgrades identified as part of the QC14 Phase I interconnection studies were derived with the inclusion of all active higher-queued generation projects without regard to corresponding desired in-service dates or actual project status. Changes to the higher-queued generation projects as well as changes to generation projects in QC14, such as withdrawals, downsizing, suspensions, or deferrals to proposed in-service dates, may allow for the identified earliest in-service to be accelerated to align with the construction timing for the plan of service and Interconnection Facilities needed to interconnect the project. Ultimately, SCD upgrades will be scheduled based on actual development of generation resources identified to meaningfully increase SCD on the identified overstressed circuit breakers as determined based on execution of Generation Interconnection Agreements or other agreements that commit a project towards development.

Notes:

1. Construction Duration Estimates and Identified Upgrades

Any construction durations identified in this section may vary. During the cluster study process, SCE includes all queued and active generation projects without regard to corresponding desired in-service dates or actual project status to identify SCD, DUs, and SCE construction duration. Such duration, of course, affects the ISD for this specific project. As status for queued projects could change (withdrawals, downsizing, suspensions, or deferred in-service dates), as a result SCE may be able to accelerate in-service dates for projects affected by status changes. Furthermore, SCE will only begin design/construction of an identified SCD and DU when enough projects 1) execute and fund a Generation Interconnection Agreement and/or a Letter of Agreement with SCE and 2) those projects trigger the need for an upgrade.

2. Coordination of Environmental Work.

Where this study assumes that the IC will perform environmental work related to the installation of SCE's IFs, and DUs as specified in this report, the IC is advised that any durations provided above assume so and that the IC will perform this environmental work and Civil Construction related to the installation of SCE's IFs and/or DUs specified in this report and will perform them in parallel with SCE's preliminary design and engineering. The IC is expected to engage SCE to obtain concurrence prior to commencement of any environmental work and during execution of that work. Since SCE will be using the IC's environmental documents and/or work products, IC delays producing them may delay SCE's ability to obtain required permits and/or license(s). Such delays would likely cause additional delays in the commencement of SCE's final engineering, procurement, and construction. These delays could increase any durations identified in this report and push out the feasible ISD provided in Table K.1 ISD and COD Assessment.

All civil construction related to SCE's IF and DUs must be completed and approved by SCE inspectors prior to SCE scheduling the electrical construction of the Interconnection Facilities and Distribution Upgrades.

3. Other Potential Costs to the Generating Facility

a. Other Potential Network Upgrades:

As part of the study results, the Generating Facility will be sharing IF and DU ("shared facilities") with a [REDACTED] project that does not have an executed interconnection agreement. If these shared facilities do not materialize because of the IC withdrawing [REDACTED], the shared facilities would still be required by the Generating Facility to physically interconnect to SCE's Distribution System. As a result, the terms and conditions for these shared facilities and their associated costs will be addressed with the IC during the GIA negotiation process. The IC's Phase I Study report reflects only the assigned IF and DU scope and cost to interconnect the Generating Facility to SCE's Non-ISO Distribution System

- b. The IC will be required to procure and construct underground duct banks and related structures required for SCE’s IF and DUs (Civil Construction⁷) in accordance with specifications and designs provided by SCE.

K. IN-SERVICE DATE AND COMMERCIAL OPERATION DATE ASSESSMENT

An ISD and COD assessment was performed for the Generating Facility to establish SCE’s estimate of the earliest achievable ISD based on the cluster study process timelines and the time required for SCE to complete the facilities needed to enable physical interconnection as an Interim Deliverability or Energy Only Deliverability interconnection (as applicable) for the Generating Facility. This date may be different from the IC’s requested ISD and will be the basis for establishing the associated milestones in the draft GIA.

1. ISD Estimation Details

For the QC14 Phase I Interconnection Study, the estimated earliest achievable ISD is derived by the time requirements to complete the following:

1. QC14 Interconnection Study Process
2. Tender a draft GIA
3. Negotiate and execute the GIA
4. Longest duration associated with the facilities required to interconnect the Generating Facility (i.e., IF, RNU, and DU), per the durations specified in table J.1. above.

Table K.1: ISD and COD Assessment

Action or Assumption	Calendar Days or Months for Calculation	Item Description	Target Date
		Issuance of Phase I Interconnection Study Report	██████████
		Issuance of Phase II Interconnection Study Report	██████████
Add:	30 CD	Phase II Results Meetings	██████████
Starting Point:		For WDTs the assumption is that the TPD Results issued and IC response provided before starting the draft GIA (the IC does have the option to start the GIA negotiation earlier)	██████████

⁷ The IC understands and acknowledges that the Civil Construction in support of the interconnection for the Generating Facility may be classified as the IC-constructed SCE IF and/or DUs and may require transfer of ownership pursuant to Section 3 (1) under Appendix C of the GIA. The IC understands and acknowledges that it shall be responsible for the ITCC and ongoing monthly IF Charge and/or DUs charge of the portion of Civil Construction and prior to the ISD of the Civil Construction, IC shall provide SCE the final invoiced costs of the portion of Civil Construction transferred to SCE and shall be an acceptable form to SCE.

Add:	30 CD	Earliest reasonable Tender draft GIA	██████████
Add:	90 CD	GIA negotiation time, execution, and related activities	██████████
Add: Construction Duration (Months)	27	Project execution duration outlined in the Study Report. Construction completion no earlier than date which reflects earliest ISD	██████████
Reference:		IC-requested ISD via IR	██████████
Reference:		IC-requested COD via R	██████████
		Duration difference between ISD and COD (months)	█
Equals:		Earliest achievable In-Service Date (ISD) per estimated project execution duration	██████████
		Earliest achievable Commercial Operation Date (COD) (Using difference between ISD and COD requested by IC)	██████████

Notes on the Achievable ISD and COD calculation:

- 1) This calculation assumes the estimated duration to construct those facilities required for the Generating Facility to achieve Interim Deliverability Status or Energy-Only Deliverability Status (as defined in the ISO Tariff) until the applicable DNU's are completed.
- 2) The project execution durations shown represents the estimated amount of time needed to engineer, design, procure, and construct the facilities from the effective date of the GIA; and timely receipt of the IC's initial specification information, written authorization to proceed ("ATP"), project payments, financial security postings, and timely completion of project milestones.
- 3) The IC-requested dates are specified in the IR submitted to SCE in accordance with GIP Section 4.6.1. Table K.1 provides SCE's estimated achievable ISD and COD for the Generating Facility in compliance with GIP Section 4.9.2. The actual ISD, Initial Synchronization Date, and COD will depend on licensing, engineering, detailed design, procurement, and construction requirements to interconnect the Generating Facility after the GIA has been executed or filed at the Federal Energy Regulatory Commission ("FERC") for acceptance.
- 4) Assumes that GIA is tendered after the TP Deliverability allocation results are disclosed, the required affidavit is submitted accepting or rejecting the deliverability allocation, and the IC has submitted written notification to SCE requesting a draft GIA.

2. ISD Conclusion

[REDACTED]

SCE can reasonably tender a draft GIA by [REDACTED]. The draft GIA should be executed and/or filed at FERC no later than [REDACTED] and will include the earliest ISD and COD as identified in Table K.1.

The ISO will perform its Annual Reassessment ([REDACTED]) and Transmission Plan Deliverability (“TPD”) Allocation⁸ ([REDACTED]). Any changes in scope, cost, or schedule requirements that come out of ISO’s Annual Reassessment and [REDACTED] TPD Allocation will be reflected in a [REDACTED] Reassessment Report, which will be used to revise the draft GIA (if under negotiation) or amend the GIA (if already executed).

⁸ The TPD Allocation Process is estimated to be completed in April 2024. The actual date may vary.

Attachment 1:
Interconnection Facilities, Network Upgrades and Distribution Upgrades
Please refer to separate document

Attachment 2:
Escalated Cost and Time to Construct for Interconnection Facilities, Reliability Network Upgrades,
Delivery Network Upgrades, and Distribution Upgrades
Please refer to separate document

**Attachment 3:
Allocation of Network Upgrades for Cost Estimates and Maximum Network
Upgrade Cost Responsibility**

Not applicable since the Generating Facility did not get allocated any Network Upgrades

Attachment 4:

SCE's Interconnection Handbook

Preliminary Protection Requirements for Interconnection Facilities are outlined in the SCE's Interconnection Handbook at the following link:

<https://on.sce.com/InterconnectionHandbook>.

Attachment 5:
Short-Circuit Duty Calculation Study Results
Please refer to the Appendix H of the Area Report

**Attachment 6:
Not Used**

Attachment 7:
Subtransmission Assessment Report
Please refer to separate document

Attachment 8:
Distribution Assessment Report
Please refer to separate document